

TOYO SUBMERSIBLE AGITATOR SAND PUMP FOR FIXED INSTALLATION WITH GUIDANCE PIPE

DPE/DPFE

FEATURE

- Special version of DP and DPF pumps dedicated to fixed installations.
- Continuous operation with high concentration by the agitation of Cutter Fan (agitator) at the bottom of pump.
- Hi-Chrome casting iron is used in Impeller, Cutter Fan and the other expendable parts and every parts have enough thickness. Low speed motor is adopted.
- The distance between Suction Cover and Impeller is adjustable and it allows best operation anytime.



DISCHARGE BORE	80~100mm
OUTPUT	2.2~55kw
SOLID SIZE	14~60mm

SPECIFICATION

MODEL	BORE (mm)	STANDARD		SOLID SIZE (mm)	MOTOR		WEIGHT (kg)	CABTYRE CABLE 10m (symbol x mm ² x core)
		HEAD (m)	CAPACITY (m ³ /min)		OUTPUT (kW)	POLE (P)		
DPE-3-2	80	7	0.5	20	2.2	4	145	3PNCT×5.5 [#] ×4C
DPE-5-2	80	12	0.5	20	3.7	4	155	3PNCT×5.5 [#] ×4C
DPE-7.5-2	80	15	0.5	25	5.5	4	195	3PNCT×5.5 [#] ×4C
DPE-7.5B-2	100	12	1.0	25	5.5	4	195	3PNCT×5.5 [#] ×4C
DPE-10-2	100	15	1.0	25	7.5	4	215	3PNCT×8 [#] ×4C
DPE-10H-2	100	20	0.8	14	7.5	4	215	3PNCT×8 [#] ×4C
DPFE-15	100	15	1.5	35	11	6	490	3PNCT×14 [#] ×4C
DPFE-15H *	100	17	1.5	35	11	6	490	3PNCT×14 [#] ×4C
DPFE-15B	150	8	3.2	60	11	6	530	3PNCT×14 [#] ×4C
DPFE-20	100	20	1.5	35	15	6	550	3PNCT×14 [#] ×4C
DPFE-20H	100	22	1.5	15	15	6	550	3PNCT×14 [#] ×4C
DPFE-20B	150	10	3.2	60	15	6	520	3PNCT×14 [#] ×4C
DPFE-30	100	30	1.5	35	22	6	750	3PNCT×38 [#] ×3C·3.5 [#] ×1C
DPFE-30B	150	15	3.2	60	22	6	710	3PNCT×38 [#] ×3C·3.5 [#] ×1C
DPFE-30BH *	150	20	3.2	60	22	6	730	3PNCT×38 [#] ×3C·3.5 [#] ×1C
DPFE-40B	200	12	6	40	30	6	750	3PNCT×38 [#] ×3C·3.5 [#] ×1C
DPFE-50	150	25	3.2	60	37	6	930	3PNCT×80 [#] ×3C·7 [#] ×1C
DPFE-50H	150	28	3.2	40	37	6	930(1030)	3PNCT×80 [#] ×3C·7 [#] ×1C
DPFE-50B	200	15	6	60	37	6	930	3PNCT×80 [#] ×3C·7 [#] ×1C
DPFE-60B *	200	22	6	60	45	6	980	3PNCT×80 [#] ×3C·7 [#] ×1C
DPFE-75B	200	28(22)	6	60(40)	55	6	1000(1100)	3PNCT×38 [#] ×3C·3.5 [#] ×1C
DPFE-75BH *	200	40	3.2	40	55	6	1100	3PNCT×38 [#] ×3C·3.5 [#] ×1C

- Specifications are changeable without notice. Please ask for Specification Sheet for the details.
- Standard equipments : Insulation class F and voltage 200V.
- Thermal protector is installed in the pump of 2.2kw-7.5kw.
- Custom made equipments are also available.
- Standard voltage of DPFE-75B and DPFE-75BH is 400V.
- * only 60Hz available.
- Figures inside () are for 50Hz.

SIZE

Unit : mm

MODEL	A	B1	B2	B3	C	E	F	G	H1	H2	J	K	L	M	N	P
DPE-3-2	840	168	168	187	705	55	37	315	320	220	30	180	230	275	280	40A
DPE-5-2	895	168	168	187	725	55	37.5	315	320	220	30	180	230	275	280	40A
DPE-7.5-2	885	193	199	215	735	35	37.5	15	330	220	30	180	230	275	280	40A
DPE-7.5B-2	890	193	209	225	780	40	40.5	335	340	260	40	200	240	295	290	50A
DPE-10-2	930	193	209	228	780	40	40.5	335	340	260	40	200	240	295	290	50A
DPE-10H-2 *	930	193	209	225	780	40	40.5	335	340	260	40	200	240	295	290	50A
DPE-10H-2 *	930	230	240	260	780	40	105	335	370	260	40	200	240	295	290	50A
DPFE-15	1395	257	253	267	1220	120	615	330	463	245	245	410	340	500	400	50A
DPFE-15H *	1395	257	253	267	1220	120	615	330	463	245	245	410	340	500	400	50A
DPFE-15B	1395	275	296	321	1220	120	630	290	535	310	260	460	400	500	460	50A
DPFE-20	1430	283	293	304	1220	120	610	610	498	245	245	410	340	500	400	50A
DPFE-20H	430	275	296	321	1220	120	630	290	535	310	260	460	400	500	460	50A
DPFE-20B	1430	275	296	321	1220	120	630	290	535	310	260	460	400	550	460	50A
DPFE-30	1510	325	333	344	1320	120	630	345	538	245	245	410	340	500	400	50A
DPFE-30B	1510	304	322	340	1320	120	650	310	565	310	260	460	400	550	460	50A
DPFE-30BH *	1510	304	322	340	1320	120	700	310	565	310	260	460	400	550	460	50A
DPFE-40B	1510	304	322	340	1320	120	700	310	565	370	260	520	400	610	460	50A
DPFE-50	1695	322	347	366	1470	120	705	365	595	310	260	460	400	550	460	50A
DPFE-50H *	1685	386	401	425	1455	105	705	365	655	310	260	460	400	550	460	50A
DPFE-50H *	1965	322	347	366	1470	120	705	365	595	310	260	460	400	550	460	50A
DPFE-50B	1695	322	347	366	1470	120	755	365	595	370	260	520	400	610	460	50A
DPFE-60B *	1735	322	347	366	1520	120	755	365	595	370	260	520	400	610	460	50A
DPFE-75B *	1775	376	401	425	1555	105	755	365	655	370	260	520	400	610	460	50A
DPFE-75B *	1785	322	347	366	1570	120	755	365	595	370	260	520	400	610	460	50A
DPFE-75BH *	1775	376	401	425	1555	105	755	365	655	370	260	520	400	610	460	50A

- Specifications are changeable without notice. Please ask for Specification Sheet for the details.
- * only 60Hz available.

DPF-3~10H-2

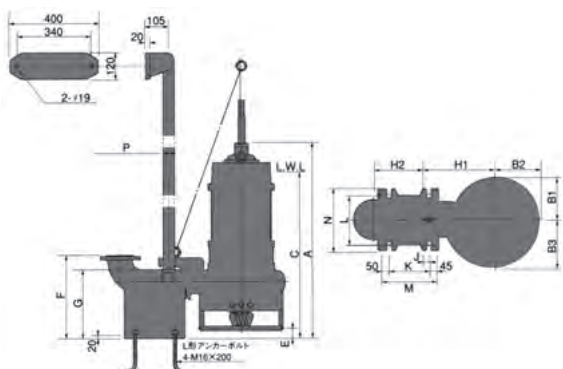

DPFE-15~75BH

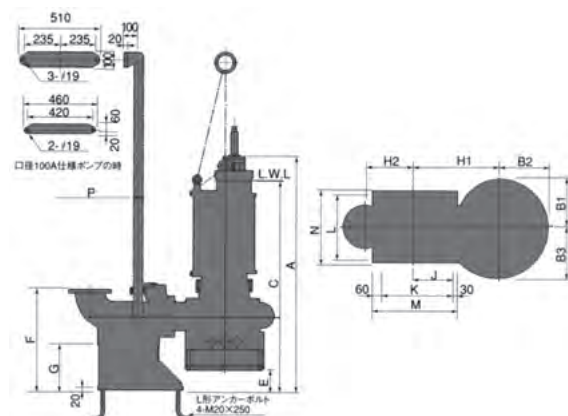

PERFORMANCE CURVES

DP

50Hz 4P...1500r/m

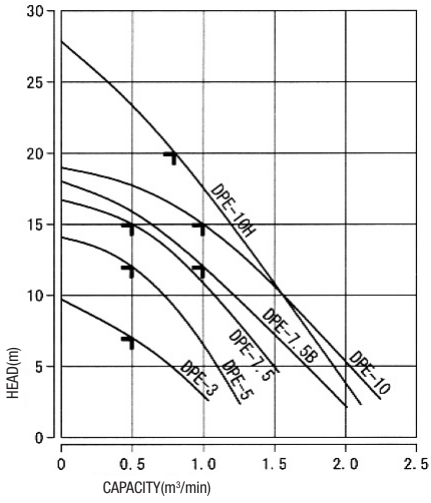

60Hz 4P...1800r/m

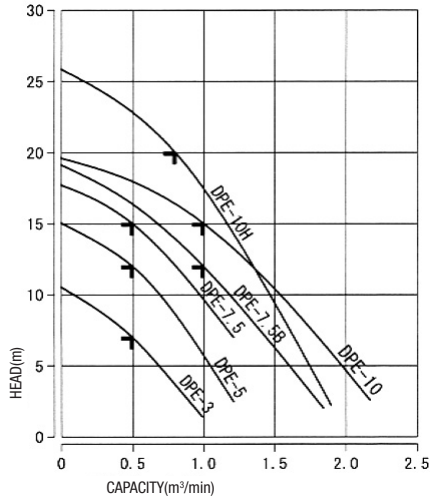

DPF

50Hz 6P...1000r/m

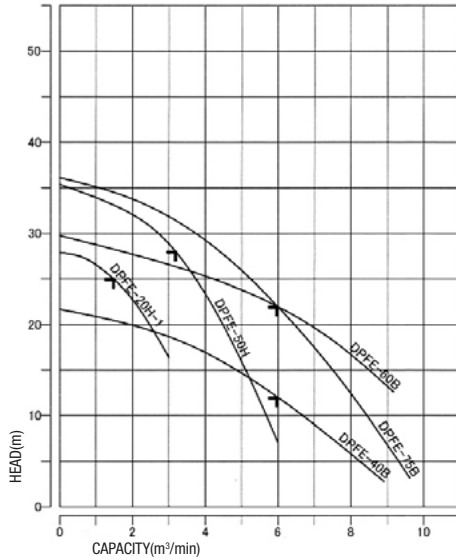
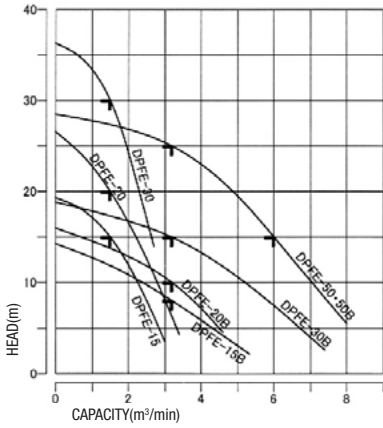

60Hz 6P...1200r/m

