

TOYO SUBMERSIBLE AGITATOR SAND PUMP

DPF-A(HIGH DEPTH)

FEATURE

- Original pressure compensation and sealing system provides high efficient operation at shallow or deep water.
- Suitable for the water depth up to 80m.
- Continuous operation with high concentration by the strong suction power and agitation of Cutter Fan (agitator).
- Extreme durability and resistance to abrasion.
- Suitable for dredger/dredging system. DP-A provides best performance for dredging at high depth.



DISCHARGE BORE	100~200mm
OUTPUT	11~55kw
SOLID SIZE	35~60mm

SPECIFICATION

MODEL	BORE (mm)	STANDARD		SOLID SIZE (mm)	MOTOR		WEIGHT (kg)	CABTYRE CABLE 10m (200V) (symbol x mm ² x core)
		HEAD (m)	CAPACITY (m ³ /min)		OUTPUT (kW)	POLE (P)		
DPF-15-A	100	15	1.5	35	11	6	530	3PNCT×14mm ² ×4C
DPF-15H-A *	100	17	1.5	35	11	6	530	3PNCT×14mm ² ×4C
DPF-15B-A	150	8	3.2	60	11	6	570	3PNCT×14mm ² ×4C
DPF-20-A	100	20	1.5	35	15	6	600	3PNCT×14mm ² ×4C
DPF-20H-1A	100	25	1.5	30	15	6	600	3PNCT×14mm ² ×4C
DPF-20B-A	150	10	3.2	60	15	6	590	3PNCT×14mm ² ×4C
DPF-30-A	100	30	1.5	35	22	6	800	3PNCT×38mm ² ×3C·3.5mm ² ×1C
DPF-30B-A	150	15	3.2	60	22	6	780	3PNCT×38mm ² ×3C·3.5mm ² ×1C
DPF-30BH-A *	150	20	3.2	60	22	6	780	3PNCT×38mm ² ×3C·3.5mm ² ×1C
DPF-40B-A	200	12	6	40	30	6	800	3PNCT×38mm ² ×3C·3.5mm ² ×1C
DPF-50-A	150	25	3.2	60	37	6	1010	3PNCT×50mm ² ×3C·8mm ² ×1C
DPF-50H-A *	150	28	3.2	40	37	6	1010	3PNCT×50mm ² ×3C·8mm ² ×1C
DPF-50H-A *	150	28	3.2	40	37	6	1110	3PNCT×50mm ² ×3C·8mm ² ×1C
DPF-50B-A	200	15	6	60	37	6	1030	3PNCT×50mm ² ×3C·8mm ² ×1C
DPF-60B-A *	200	28	6	60	45	6	1070	3PNCT×38mm ² ×3C·3.5mm ² ×1C
DPF-75B-A *	200	28	6	60	55	6	1080	3PNCT×38mm ² ×3C·3.5mm ² ×1C
DPF-75B-A *	200	22	6	40	55	6	1180	3PNCT×38mm ² ×3C·3.5mm ² ×1C
DPF-75BH-A *	200	40	3.2	40	55	6	1180	3PNCT×38mm ² ×3C·3.5mm ² ×1C

- Specifications are changeable without notice. Please ask for Specification Sheet for the details.
- Standard voltage of DPF-75B-A and DPF-75BH-A is 400V.
- * only 50Hz available.
- * only 60Hz available.

SIZE

Unit : mm

MODEL	A	B	C	D	E	F	G	H	I
DPF-15-A	1330	750	1100	380	445	500	100	240	298
DPF-15H-A *	1330	750	1100	380	445	500	100	240	298
DPF-15B-A	1330	841	1100	380	445	560	150	255	333
DPF-20-A	1365	825	1100	380	515	495	100	280	313
DPF-20H-1A	1365	825	1100	380	535	495	100	280	313
DPF-20B-A	1365	841	1100	380	445	560	150	255	333
DPF-30-A	1442	910	1200	415	635	515	100	320	333
DPF-30B-A	1442	955	1200	415	510	580	150	310	363
DPF-30BH-A *	1442	955	1200	415	510	580	150	310	363
DPF-40B-A	1442	1010	1200	415	510	600	200	310	393
DPF-50-A	1630	1020	1350	460	560	635	150	340	383
DPF-50H-A *	1630	1020	1350	460	560	635	150	340	383
DPF-50H-A *	1635	1094	1350	460	660	650	150	350	443
DPF-50B-A	1630	1065	1350	460	560	655	200	340	413
DPF-60B-A *	1670	1065	1400	460	560	655	200	340	413
DPF-75B-A *	1705	1145	1450	460	660	670	200	350	473
DPF-75B-A *	1700	1065	1450	460	560	655	200	340	413
DPF-75BH-A *	1705	1145	1450	460	660	670	200	350	473

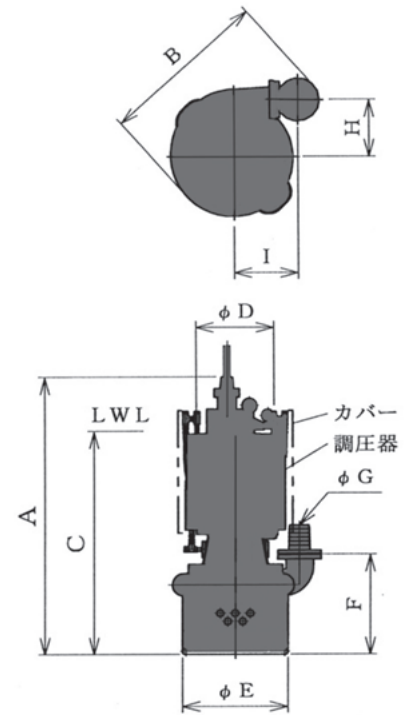

- Specifications are changeable without notice. Please ask for Specification Sheet for the details.
- Standard voltage of DPF-75B-A and DPF-75BH-A is 400V.
- * only 50Hz available.
- * only 60Hz available.

PERFORMANCE CURVES

